



TECHNICAL DATA

GENERAL		T 144 H
Load capacity	lb	2,700
Load capacity at maximum height	lb	1,695
Maximum height	ft	13.1
Maximum lift under maximum load	ft	11.1
Maximum reach	ft	5.5
Maximum load at maximum reach	lb	1,200
Unladen weight *	lb	5,571
Transmission	-	Hydrostatic auto control
ENGINE		
Make	-	KUBOTA
Model	-	V1505-E4B
Power	hp	24.8
Torque	Nm@rpm	92.6@1,700
No. cylinders	-	4
Emissions	-	Tier4
Ambient noise	dB(A)	101
DRIVING		
Maximum speed	mph	11.4
Gradeability under full load	%	25
Traction	-	4x4
Front tyres	-	11.0/65x12
Rear tyres	-	11.0/65x12
HYDRAULIC SYSTEM		
Flow rate	gal/min	5.5
Working pressure	psi	3,481
TANK CAPACITY		
Fuel	gal	14.5
Hydraulic	gal	8.4
BRAKES		
Service	-	Hydrostatic - Retention
Parking	-	Mechanically applied hydraulically released inside the hydrostatic motor

* It may change due to optional equipment

DIMENSIONS

AUSA carriage

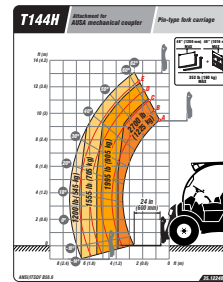

Universal & EURO8 carriage

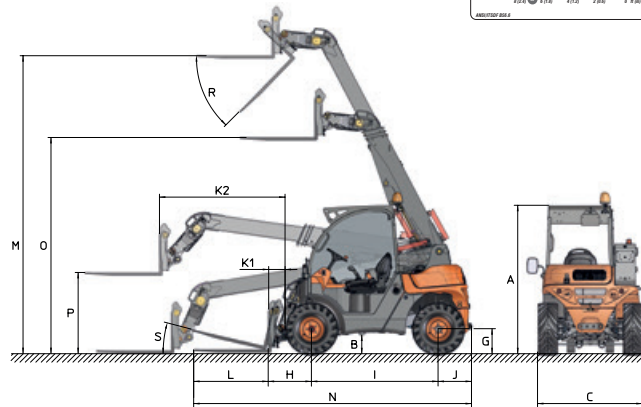
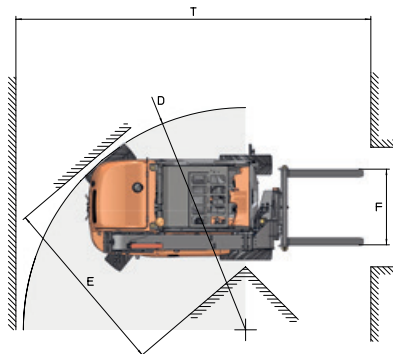
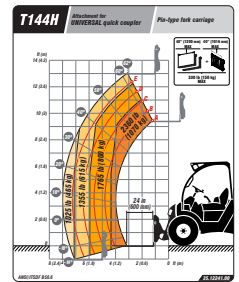

DIMENSIONS (in)		T 144 H
A		78.7
B		9.9
C		55.3
D		117.4
E		97.7
F		39.9
G		13.2
H		22.8
I		66.9
J		17.7
K	8.98	66.22
L		39.4
M		157.5
N		146.8
O		115.3
P		43.1
T		186.2
DIMENSIONS (°)		
R		46
S		13

▲ 1

▲ 2



www.ausa.com

Products are subject to modifications without prior notice. Images throughout the spec sheet may refer to non-standard machines or non-available configurations depending on models.

AUSA's logo and corporate identity are property of the Company, they cannot be used without authorization.